

## GaN MMIC Foundry Services

*Proven technology enabling high-power, multi-octave amplifiers & switches*

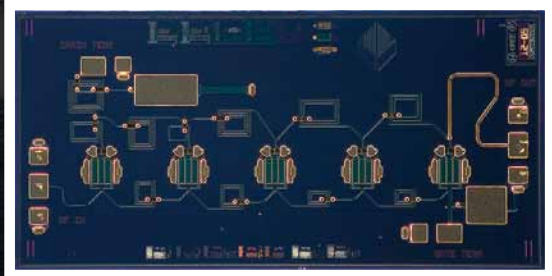

Cree offers foundry services for development and production using GaN HEMT MMIC processes in two basic families; a 0.4  $\mu\text{m}$  gate length HEMT that can be operated at drain bias of 28 to 50 V and a 0.25  $\mu\text{m}$  gate length HEMT that can be operated at 28 to 40 V. There are competitively priced options for dedicated and shared lots. Customers can design into the foundry using ADS or MWO design kits or have Cree perform the design service. The processes feature high-power density (4 to 6 Watts/mm) transistors, slot vias, resistors, capacitors, high-reliability up to 225°C operating junction temperatures, and scalable unit FET cells. Both the processes and the design kit models are extremely robust enabling first-pass design success with first-to-market of your high-power, high-efficiency MMIC products.

## FULL-WAFER SERVICE FOR GaN MMICs

Cree offers non-linear, scalable GaN HEMT models for MMICs, as well as full PDKs for both AWR's Microwave Office® (MWO) and Agilent Technologies' Advanced Design System (ADS).

Stage	Duration (Typical)
Preliminary Design Review	4 Weeks
Critical Design Review	4 Weeks
MMIC Fabrication	8 Weeks
MMIC Testing	2 Weeks
Final Review	2 Weeks
Delivery	24 Weeks ARO

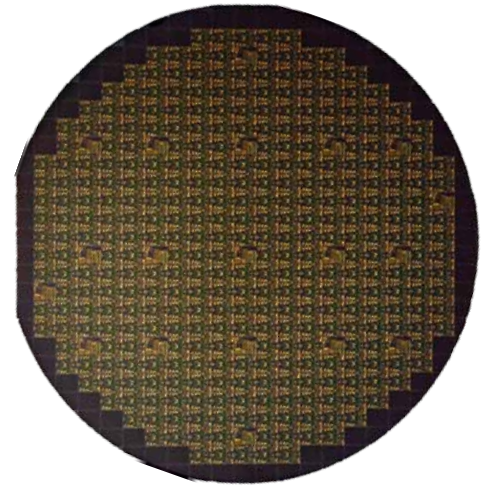

- Custom designs
- DRC, layout and model support
- 10 mm X 10 mm reticule size
- 4 PCM good wafers, 2 parameter on-wafer testing
- Production mask & wafer quantities

## SHARED MASK SERVICE FOR GaN MMICs

Cree offers the SMS service with reduced cost and MMIC size, providing multiple customers the opportunity to get their MMIC designs fabricated faster. Available areas from 2mm x 2mm to 6mm x 6mm. Forty die will be delivered. See [www.cree.com](http://www.cree.com) for details. The typical duration is 12 weeks.

Shared RTP	Schedule
DRC Clean GDS & PO	Start
MMIC Fabrication	8 weeks
MMIC Testing	2 Weeks
Final Review	2 Weeks
Delivery	12 Weeks

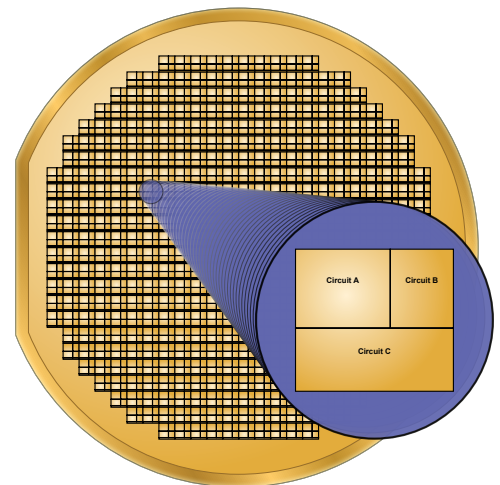

Custom Reticule

- Limited DRC, model & layout support, on-wafer electrical testing

## GaN HEMT MMIC PROCESS COMPONENTS

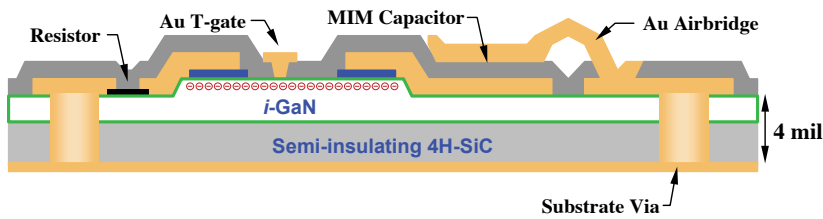

Features	G28V3 MMIC	G28/40V4 MMIC	G50V3 MMIC
Gate Length	0.4 $\mu$	0.25 $\mu$	0.4 $\mu$
Bias	28 V	28 V to 40 V	50 V
Breakdown	>120 V	>120 V	>120 V
Density	4.5 W/mm	6 W/mm	8 W/mm
Performance	DC - 8 GHz	DC - 18 GHz	DC - 6 GHz
Dual-metal 3 $\mu$ -thick Interconnects	●	●	●
Thin Film & Bulk Resistors	●	●	●
MIM Capacitors >100 V	●	●	●
Slot Substrate Via's	●	●	●
Power FETs & Switch FETs	●	●	●

## APPLICATIONS

- 2-Way Private Radio
- Test Instrumentation
- Broadband Amplifiers
- EW Jammers
- Class A, AB, Linear amplifiers suitable with OFDM, QPSK, QAM, FM waveforms
- Radar
- Military Communications

## SERVICE FEATURES

- Agilent ADS & AWR MWO Process Design Kits (PDK)
- Layout Support and DRC
- Development lots in dedicated & shared mask options
- Electrical test services available
- Visual screening
- Typically 4 PCM good wafers for FWS service
- Delivery in Gel Paks or tape frames
- Testing of two parameters
- SMS Pizza Mask Service

## CIRCUIT TYPES

- FET Limiters
- High power FET Switches
- High Power FET Amplifiers
- High IP3 FET Mixers
- Broadband Amplifiers
- High Efficiency Amplifiers
- High IP3 Amplifiers
- Multi-function Integrated MMICs

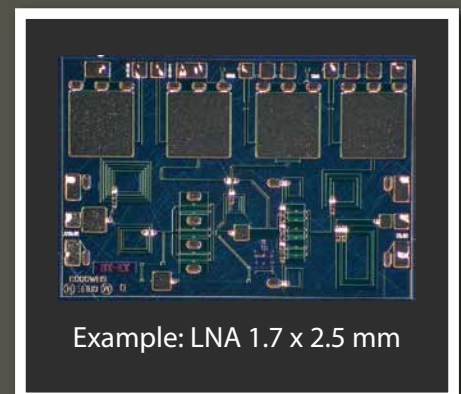
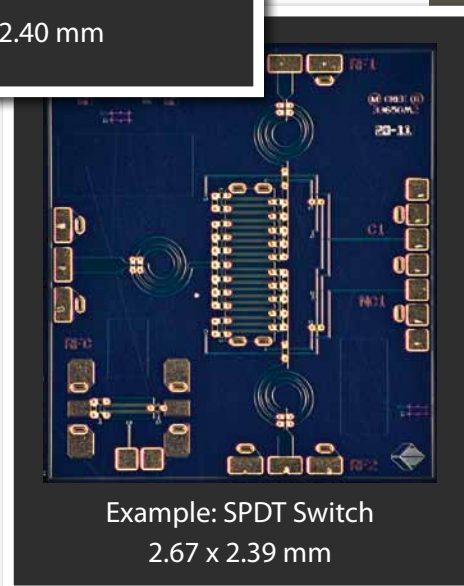
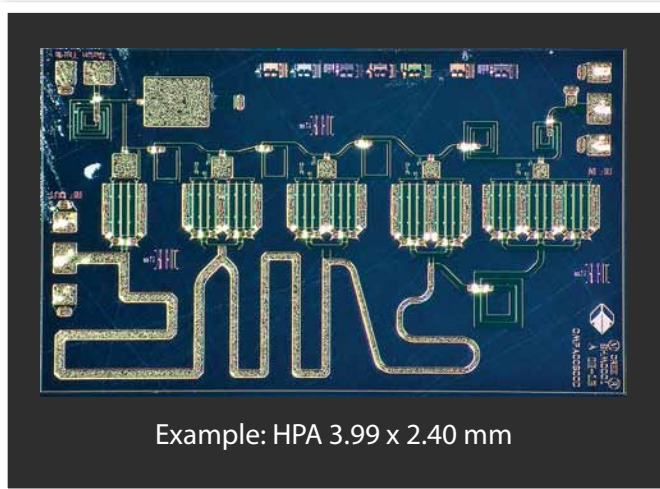



## GAN HEMT MMIC PROCESS DESIGN KIT

Available for AWR's Microwave Office



- Cree's scalable non-linear model
- All passives created with Cree design rules
- Full schematic driven layout
- Real time design rule checking
- AWR test design example: DC-6 GHz Drive Amplifier

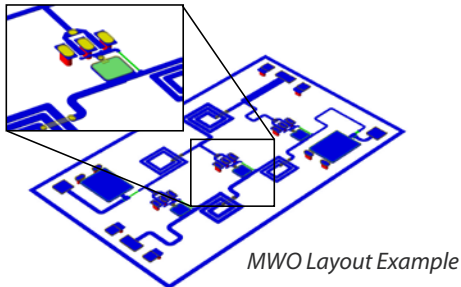

MWO Layout Example

## GAN HEMT MMIC PROCESS DESIGN KIT

Available for Agilent's ADS



**Agilent Technologies**

- Cree's scalable non-linear model
- All passives created with Cree design rules
- Design rule checking

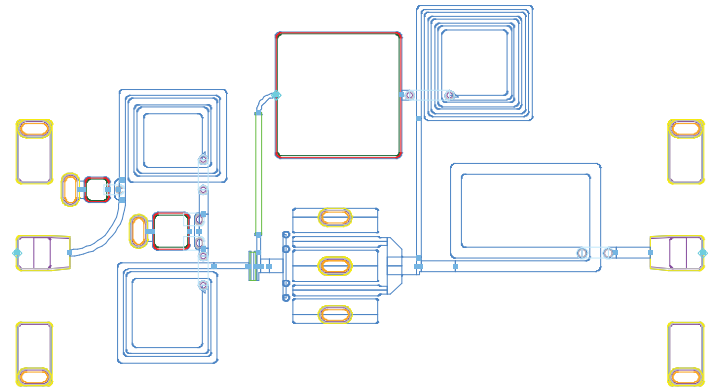

## ABOUT CREE INC.

Cree is a market-leading innovator of semiconductor solutions for wireless and power applications, lighting-class LEDs, and LED lighting solutions. Cree's product families include power-switching devices and radio-frequency/wireless devices, blue and green LED chips, high-brightness LEDs, lighting-class power LEDs, and recessed LED down lights. Cree solutions are driving improvements in applications such as variable-speed motors, wireless communications, general illumination, backlighting and electronic signs and signals.

Cree drives its increased performance technology into multiple applications, including exciting alternatives in brighter and more-tunable light for general illumination, backlighting for more-vivid displays, optimized power management for high-current, switch-mode power supplies and variable-speed motors, and more-effective wireless infrastructure for data and voice communications. Cree customers range from innovative lighting-fixture makers to defense-related federal agencies.

A publicly traded company founded in 1987, Cree now employs more than 1,500 people at its Durham, NC, headquarters and has additional offices in Santa Barbara, CA, and Asia. The Cree facility is ISO/TS 16949 certified.



## CONTACT

For inquiries and sample requests, please contact the Cree Wireless team at: 919-313-5300 or [Cree\\_Foundry@cree.com](mailto:Cree_Foundry@cree.com)

Large Signal Models Available