

The Story of Mode S

Emily Chang, Roger Hu, Danny Lai,
Richard Li, Quincy Scott, Tina Tyan

6.933 - December 15, 2000



Contents

1	Introduction	4
1.1	A Project History of Mode S	5
2	Project Beacon	6
2.1	The Project Beacon Task Force	6
2.2	ATCRBS	7
2.3	Deployment Schedule	8
3	The Air Traffic Control Advisory Committee	10
3.1	Origins	10
3.2	Proceedings	11
3.3	Recommendations	11
4	The Players	13
4.1	Aircraft Owners and Pilots Association (AOPA)	13
4.2	Federal Aviation Administration	14
4.3	Lincoln Labs	14
5	Factors that Contributed to New Technology Development	16
5.1	Widespread Frustration	16
5.2	Government Reorganization	16
5.3	The Vietnam War	17
5.4	FAA Contract with Lincoln Labs	17

6	Mode S Development	19
6.1	Mode S Overview	19
6.2	Backward Compatibility	20
6.2.1	Frequency Choice	21
6.3	Transparency	22
6.3.1	Invisibility	23
6.3.2	Sidelobe Suppression	23
6.3.3	Taking Advantage of Sidelobe Suppression	24
6.3.4	Modulation	26
6.3.5	Summary	28
7	Aftermath	29
7.1	A Slow Adoption	29
7.2	An Accident Spawns Change	29
7.3	TCAS	30
7.4	The Mode S Legacy	30
7.4.1	Traffic Information Service	31
7.4.2	Graphical Weather Service	31
7.5	Mode S Extended Squitter	32
7.6	Success and Failure	33
8	Conclusions	35
9	Acknowledgments	37

List of Figures

2.1	Datalink Overview	7
2.2	The Old Air Traffic Control System	8
4.1	Lincoln Laboratories	15
6.1	Mode S Overview	20
6.2	Mode S Ground Station and Antenna	21
6.3	Interoperability: ATCRBS and Mode S	22
6.4	Frequency Spectrum	22
6.5	ATCRBS Broadcast without Omnidirectional Antenna	24
6.6	ATCRBS Broadcast with Omnidirectional Antenna	25
6.7	ATCRBS Broadcast Pulses	26
6.8	Mode S Signal with Sidelobe Suppression	26
7.1	A Traffic Information Service Display in a Cessna	32
7.2	Graphical Weather Service Cockpit Display	33
7.3	Mode S Extended Squitter System	34

Chapter 1

Introduction

As the head of the Radar Division at MIT's Lincoln Laboratory in 1968, Herbert Weiss often traveled from Boston to Washington D.C. to work on projects with the Air Force. At that time, the commercial jet had just been introduced and had led to an unprecedented growth in civil aviation. Weiss was frequently frustrated by flight delays during his trips, and wondered if he might be able to do something about it. One day, he knocked on the door of the Federal Aviation Administration (FAA) building in D.C. and introduced himself; this simple act began a decades-long relationship between Lincoln Labs and the FAA.

The air traffic control system during the 1960's was a patchwork of technologies. Overworked air traffic controllers collated information from a wide variety of sources – radar, radio, and flight plans – in order to maintain a sense of aircraft location and trajectories. Some still tracked planes using plastic markers, moving them around on a map when new radar updates arrived. Because the FAA did not have the resources to fully deploy new technologies, many ground stations continued to use the same equipment that had been in place for the last twenty years. Unfortunately, the antiquated systems were simply unable to keep up with the “burgeoning need” and delays and even collisions occurred [1].

Weiss was not the only one to conclude that the air traffic control system needed to be overhauled. In the summer of 1968, the Department of Transportation, pressured by increased concerns about recent mid-air collisions, formed a committee to explore the requirements for the next generation of air traffic control technologies. The resulting recommendation was to develop an air traffic control technology capable of bidirectional, one-to-one, ground-to-air communication. Lincoln Labs took on the role of proving the feasibility of this plan, and would ultimately design, prototype, and produce a final specification for the new technology.

This technology was Mode S.

1.1 A Project History of Mode S

This report traces the history of the development of Mode S from 1961 to 1975. Beginning with the pressures that culminated in the development of a new air traffic control technology, we considered the requirements for the new system, examined the choice of Lincoln Labs as its designer and traced the design decisions that went into the final specification for Mode S.

The analysis focuses on the key requirement for Mode S: interoperability with existing air traffic control systems. Even though the exigency of a new infrastructure was obvious, the diverse concerns of the aviation community, the large number of aircraft, and the need to extensively test any new system collectively formed a high barrier to adoption for any new technology. The Lincoln Lab designers of Mode S were acutely aware of this problem and were determined to build a new air traffic control technology that would interoperate seamlessly with the existing system.

An important theme is illustrated by the struggle with interoperability and more importantly, the pressures that compelled this requirement. Mode S was largely influenced by the community it was designed for, the researchers that designed it, and the agency that funded its development. To put this observation in the larger context, the design of any real-world, complex system is and should be driven by its environment; successful technologies cannot be developed in isolation.

Chapter 2

Project Beacon

On December 16, 1960, a midair collision occurred over New York City, when the pilot of a United Airlines DC-8 overshot his designated airspace and collided into a TWA Constellation, killing 128 passengers and 8 people on the ground. This collision brought the problem of air traffic control into the public eye, stirring the government into action and bringing to the surface many underlying problems with the national air traffic control system. Facing criticism from both the aviation community and the government, the Federal Aviation Agency (FAA) quickly began a reassessment of its existing system and research program [2].

2.1 The Project Beacon Task Force

President John F. Kennedy issued an order on March 8, 1961 requesting the FAA to “conduct a scientific, engineering overview of our aviation facilities and related research and development and to prepare a practicable long-range plan to insure efficient and safe control of all air traffic within the United States.” A task force called “Project Beacon” was established that would report its findings to the FAA administrator [3].

Project Beacon was faced with two strong, competing factions in the choice of the next generation of air traffic control. The Research and Development Bureau of the FAA had focused on the development of the most advanced ATC equipment possible, a Data Processing Central computer and 3-D radar, neither of which had been completed. They believed that, once perfected, these technologies would revolutionize air traffic control. The air traffic controllers who used the actual system on a day-to-day basis pushed for the modernization and improvement of existing, proven technologies, especially radar. They felt that this solution would provide a more immediate fix to the problems facing air traffic control, while the engineers’ new technology was still many years from completion [2].

The final recommendations of the Project Beacon task force agreed more strongly with the controllers than the engineers, concluding that an improved radar system would be the primary tool for air traffic control for at least the next decade. Whereas previously

controllers kept track of airplanes on the radar screen with flight strips, plastic markers (“shrimp boats”), and grease-penciled markings on the radar screen, the system would now be upgraded to display altitude and identification visually in alphanumeric characters on the radar screen [2]. The amount of controller workload would thus be reduced and help eliminate much of the confusion in air traffic control.

2.2 ATCRBS

The system introduced was the Air Traffic Control Radar Beacon System (ATCRBS). It was adopted from the military’s Identification Friend and Foe (IFF) system, which had been used by the British Royal Air Force extensively during World War II. IFF allows a ground-based transmitter to broadcast a radio signal that would interrogate a nearby plane. If the plane equipped with a transponder does not respond with the proper reply, it is assumed to be an enemy aircraft.



Figure 2.1: Datalink Overview

The ATCRBS system operates under the same principles, as an interrogation-based system that utilizes signals modeled after those used in the IFF system. Interrogations are broad-

cast from a rotating antenna, and any aircraft carrying ATCRBS transponders within that antenna's beam will respond to the interrogation. There are two primary types of interrogations; Mode A (Mode 3 in IFF) provides the aircraft's identity, while Mode C encodes the aircraft's altitude information. ATCRBS also shares the same frequency bands as IFF: 1030 MHz for interrogations and 1090 MHz for replies [4].

ATCRBS fits into the air traffic control system as a secondary surveillance system, working in conjunction with radar. While primary radar detects the presence of aircraft in the sky, ATCRBS provides additional information such as altitude and identification. This allows controllers to track and direct the individual planes. It requires two specific pieces of equipment, the transponder on the aircraft, and the transmitter-receiver on the ground [5].

However, ATCRBS has its limitations. The fact that all aircraft within an antenna's interrogation beam will reply to the interrogation means that the more airplanes there are in the sky, the more replies the ground station will receive. This causes the 1090 MHz channel to become overloaded with replies. When replies overlap, interference occurs, and the ground station receives garbled signals which it is unable to use. This problem derives partly from the fact that the original military system on which ATCRBS was based was not designed for the scale of civilian aviation. The number of airplanes an IFF system had to keep surveillance of at a given time was relatively low. As civilian traffic increased, ATCRBS became increasingly unable to provide effective surveillance [3].

2.3 Deployment Schedule



Figure 2.2: The Old Air Traffic Control System

The deployment of Project Beacon and the ATCRBS system did not go as planned. Although the FAA did begin to act on the plan, by 1965 it was clear that there was a wide separation between what the system promised and what it actually could do. Many controllers were

still using the old manual “shrimp boat” system (see Figure 2.2), despite the fact that air traffic growth had jumped over 75% since the early 60’s.

Project Beacon made a number of inherently wrong assumptions in its proposal for a new system, grossly underestimating the technical problems involved in the task. Estimates were based on the development of the military’s SAGE system, which was designed to solve an entirely different, smaller class of problems than civilian air traffic control. The Beacon task force had also expected equipment and research development efforts to remain at the same level as in 1961. However, FAA budgets were cut through the 1960’s, and funds originally intended for airspace programs were diverted into other areas. Thus, equipment for the new system was being deployed at a slower pace than had been originally planned. At the same time, the level of air traffic growth had not been predicted, and the new system was not prepared to meet the new level of demand [2].

By the late 1960’s the air traffic control system was once again in disarray. With the budget so low, the FAA could only maintain the existing system, rather than improve it. At the same time, cutbacks were being made in personnel, and the main air traffic control training facility was closed down. By 1967, there was a shortage of air traffic controllers, and those who remained had to handle the rapidly-increasing traffic with outdated equipment [2]. Congestion at airports was increasing nationwide, and flight delays skyrocketed. Although organized controller “slowdowns” and “sick-outs” prompted the FAA to accelerate its deployment of the automated systems recommended by Project Beacon, the FAA was still far behind its original schedule of deployment [3].

Chapter 3

The Air Traffic Control Advisory Committee

In 1967, two fatal collisions of general aviation aircraft and air carrier aircraft occurred; one in Urbana, OH where 26 people were killed, and one in Hendersonville, NC, where 82 people died. These collisions once again raised a flag in the public's awareness that there were problems with the air traffic control system, and helped push the newly formed Department of Transportation (DOT) into forming a committee that would conduct an in-depth study of air traffic control.

3.1 Origins

This committee, the Air Traffic Control Advisory Committee (ATCAC), was created in 1968 and put under the control of Larry Goldmuntz, who was in the office of the Assistant Secretary for research and technology in the DOT. Its purpose was to examine the state of air traffic control, project growth in air traffic, and recommend an ATC system for the 1980's and beyond. The recommendations were to be used as the basis for a new development program.

Larry Goldmuntz began recruiting people from industry, academia, and government agencies to join the committee. These people had strong backgrounds in a variety of areas, including air defense/surveillance, communications, and economics, to join the committee. Among these were Jack Ruina of MIT, who recommended Ben Alexander, "an outstanding technical person" who "also happened to be a private pilot" to act as chairman - he turned out to be "a marvelous choice" [6]. The technical staff of 150 were drawn from all segments of the aviation community, the FAA, NASA, and the Department of Defense. The committee also maintained liaisons with various aviation organizations, including the military, NASA, AOPA, and many others, thereby receiving advice on both the technical and policy levels from all affected parties [7].

3.2 Proceedings

In order to come up with a viable solution, the committee developed a methodology of systems analysis and requirements development. Forecasted user needs defined the requirements, various system alternatives were developed to meet these requirements, and then a preferred system was selected on the basis of cost, technical risk, implementability, and performance [7].

User needs were determined by talking with people from different parts of the aviation community, “not just to find out what they have to say but also so they know their thoughts are taken into account in the committee’s decisions.” Because the aviation community includes groups with widely divergent interests, such as technical advisors, pilots, controllers, small airplane owners, airline and airport owners, as well as equipment manufacturers, any proposed change involved a great deal of research [8]. At the same time, the committee studied air traffic and its projected growth and predicted that aviation activity would double by 1980, and then double again by 1995. Correspondingly, demands for ATC service would rise even faster, tripling by 1980 and then again by 1995 [7].

After examining the system, the committee determined that ATCRBS as it stood was too limited to handle the predicted increases in traffic. It lacked accuracy and reliability of position data and had limited capabilities. The frequencies they used were overloaded, which resulted in data loss and garbling. Garbling occurred when there were timing conflicts between two planes replying to different interrogators, when planes within a certain range replied to the same interrogator and their signals overlapped, or when multipath reflections occurred that distorted the signals. In order to solve these problems, ATCAC investigated a number of different system alternatives, from completely replacing ATCRBS to suggesting modifications/upgrades to the existing system. The final recommendation of ATCAC was to upgrade ATCRBS, allowing it to handle traffic into the 1990s [7].

3.3 Recommendations

The ATCAC proceedings in the late 1960’s resulted in a vision for future air traffic control systems and technologies extending well into the 1980’s. In order to achieve this vision, ATCAC suggested upgrading ATCRBS, the existing surveillance technology, changing runway and air separation standards, and possibly developing collision avoidance systems [7]. The significant features of the recommended ATCRBS upgrade were indicative of the main concerns that ATCAC considered: cost, implementability, and performance.

Essentially, ATCAC felt that better air traffic control depended on a two way point-to-point air-to-ground data link, with better data transfer rates than previous technology [7]. By improving beacon technology, this data link could be incorporated into the current ATCRBS system for obtaining aircraft identification and altitude information.

The fundamental problem with existing beacon communication was an overload of the al-

located frequencies, 1030 MHz for interrogations and 1090 MHz for replies. To increase the scalability of beacon communications, ATCAC advised the use of discrete addressing to reduce the amount of traffic on the assigned communications channels. Discrete addressing would mean that only the targeted aircraft would respond to any given interrogation, rather than all aircraft in the range of the beacon. Additionally, if beacon technology were improved, it would require fewer interrogations and replies for a given aircraft.

ATCAC was extremely sensitive to the needs of the user; it recognized that aircraft owners and airlines could not easily replace their old system with an entirely new one. Therefore, it unanimously agreed that ATCRBS should be upgraded, rather than replaced by an entirely separate system. Any new technology that was developed would have to be completely interoperable with ATCRBS to accommodate those who did not adopt the new system. This decision was made despite the fact that ATCAC had “basically been charged with a fresh piece of paper to look at air traffic control.” [8] The motivation for this was primarily to minimize deployment costs in order to facilitate acceptance of the new technology within the conservative aviation community. Additionally, the distributed nature of the air traffic control system made it implausible to enforce an instantaneous conversion from one system to another. Based on recommendations from technical experts, ATCAC concluded that incremental upgrade was feasible, and that the benefits of reduced risk and cost outweighed the increased design difficulty of the new system.

Chapter 4

The Players

The primary players in the creation of the specifications and design of the Mode S system were the Aircraft Owners and Pilots Association (AOPA), the Federal Aviation Administration (FAA), and Lincoln Labs. The AOPA were a strong lobbying force for the interests of the general aviation community. Lincoln Labs was the technical arm working on the actual technology, while the FAA acted as a go-between between the aviation community and Lincoln. The FAA was also the legislative and governmental force that would decide whether or not the technology was viable.

4.1 Aircraft Owners and Pilots Association (AOPA)

One of the most powerful voices influencing the FAA and ATCAC's decision to make the new system completely interoperable with the old was the Aircraft Owners and Pilots Association (AOPA). The Aircraft Owners and Pilots Association was formed in 1939, with the goal of making "general aviation fun, safe, and affordable." [9] The organization faced its first major challenge during World War II, when the government attempted to ban all civilian flying. The AOPA helped fend off this measure by establishing an identification program, but continued to be skeptical of future government regulation efforts [9].

As air traffic control efforts increased, the AOPA fought to keep costs of mandatory equipment low, and increased in size and influence. AOPA also helped pilots by educating them about new navigation tools, and published several informative magazines designed for the general aviation community. More importantly, the AOPA legislative lobbying group became stronger and led general aviation in efforts to reduce costs and potential restrictions [9].

The AOPA was to some extent motivated by the desire to increase membership and often modified its official views to match those of prospective members. As an example, in the early 1960's, a new FAA Administrator was appointed, and the AOPA initially had hopes that this change would result in a more favorable climate for general aviation. However, conciliatory efforts did not win the AOPA many new members since they were much more

visible when resisting new FAA regulations [2].

Generally, the AOPA did adhere to its original motives of making flying safe and inexpensive, and they served an important role in representing the general aviation community and its interests. Their philosophy was best summarized by Max Karant, the founding editor of the AOPA Pilot and a prominent leader in the AOPA, “Whatever ultimate system we come up with must serve all pilots who wish to use it.” To this end, the AOPA consistently fought off “efforts to price [private flying] out of the air with costly, unnecessary equipment requirements and more and more airspace regulations.” [10] The AOPA’s influence was so strongly felt that even the development of new technologies was influenced by the general aviation community’s desire to keep flying costs as low as possible.

4.2 Federal Aviation Administration

The collision of two aircraft over the Grand Canyon in 1956 that killed 128 people raised awareness that the existing systems of aircraft separation were not appropriate for the increasingly crowded skies. Subsequently, the FAA was formed as the Federal Aviation Agency in 1958 with the passing of the Federal Aviation Act. Its purpose was to establish and run a broad air traffic control system to maintain safe separation of all commercial aircraft through all phases of flight. It was also given jurisdiction over all other safety-related matters for aviation [11].

In reality, the FAA’s control over aviation matters was not complete, since, as a government agency, they needed to balance the needs of the various politically active factions of the aviation community. Additionally, the FAA tended to rely on external advisors in technical matters. Therefore, when the ATCAC report indicated that a new air traffic control system was needed, the FAA looked for a suitable agency to carry out the task of designing such a system [12].

4.3 Lincoln Labs

Lincoln Labs was originally established to deal with a different type of surveillance problem: detecting enemy military aircraft. The Department of Defense felt that a plausible scenario existed where Soviet bombers with nuclear weapons would “fly over the north polar region at high latitude and then descend as it approached its target.” Ground radar could be detected and avoided, making the aircraft virtually undetectable [13].

Over the years, Lincoln continued its efforts with surveillance technologies. In 1949 the Air Force contracted Lincoln to work on the “Semi-Automatic Ground Environment” (SAGE) system. This system used multiple radar sites to display all the aircraft within a designated area on the radar screen, making it possible for military controllers to vector air defense fighters toward invading enemy aircraft [13].



Figure 4.1: Lincoln Laboratories

SAGE, a system of radar stations linked to a centralized digital computer, was essentially a predecessor to modern air traffic control systems. Because of these previous ventures, Lincoln Labs researchers had extensive knowledge of radar and communications. When the FAA finally decided to fund Lincoln Labs to design a new technology, the Air Traffic Group was officially formed. There were originally 5-6 members in the group, recruited from the other divisions at Lincoln, primarily the Radar and Communications Group.

Many of those involved with the initial development of Mode S had graduated from MIT with backgrounds in electrical engineering and communications design. Paul Drouilhet, for instance, had participated in the development and test of long-range, air-ground communications. Other members included Herb Weiss ('40), Edward Kelly ('45), Walter Wells ('52), George Colby ('53), Thomas Goblick ('58), Jerry Welch ('59), and Bill Harman ('68).

Chapter 5

Factors that Contributed to New Technology Development

During the late 1960's, several different factors combined to motivate the development of a new air traffic control technology.

5.1 Widespread Frustration

Problems with air traffic control started to become more obvious to passengers as flights became increasingly delayed. Among the travelers who noticed this problem was Herb Weiss, the head of the Radar Division at MIT Lincoln Laboratory at that time. Weiss had been working on a contract with the Air Force and often commuted to Washington, D.C. During one of his trips, he visited the FAA building and discussed the possibility of collaboration. In addition, he helped form an ad hoc committee at Lincoln Labs to determine whether Lincoln could use its expertise to help solve the air traffic control problems [13].

5.2 Government Reorganization

Meanwhile, when President Johnson took office in late 1963, he commissioned several task forces to point out areas that needed special attention. Among the recommendations made by these task forces was the creation of a transportation department to organize all Federal transportation activities into one structure. At the time, no one expected anything to come of this recommendation, since similar ideas had been dropped in the past. However, Johnson proved his determination to carry it through when he announced his attention to create a new Department of Transportation in his 1966 State of the Union address [2].

Such a significant reorganization of government agencies required a great deal of planning and legislation to work out the exact details and division of responsibilities. After an organi-

zational plan was drawn up, it was sent to Congress for approval. However, several members of Congress objected to portions of the plan, and a lengthy legislative battle ensued. It wasn't until April of 1967 that Congress finally approved the bill and the department was formed [2].

Among the changes made was the placement of the FAA under the control of the new Department of Transportation. The FAA was also renamed the Federal Aviation Administration. These changes represented a downgrading of the FAA's stature. Instead of reporting directly to the President, the FAA administrator now answered to the Secretary of Transportation. At this time, the Department of Transportation underwent a thorough assessment of its new responsibilities, including air traffic control. This assessment, combined with the impetus of the recent collisions and other problems, led to the formation of ATCAC in order to conduct an in-depth investigation of the situation [14].

5.3 The Vietnam War

At the same time, the ongoing war effort in the Vietnam War shifted emphasis and funding from military research to military applications. Because of the diminishing research budget, the Department of Defense encouraged its labs, including Lincoln, to demonstrate the usability and relevance of their work in non-military areas. Given Lincoln Labs' experience in radar, communications, and military air surveillance, civilian air traffic control seemed to be a feasible area to explore. To this end, an Ad Hoc Committee on Air Traffic Control was formed within Lincoln Labs. Their conclusion was that Lincoln could uniquely contribute to the field, and the Radar Division was subsequently restructured in 1970 into the Air Traffic Control Division [13].

The budget cuts due to the war extended to other government agencies as well, including the Department of Transportation. These budget cuts prevented the FAA from being able to upgrade to newly developed technologies and caused a shortage in air traffic controllers [13]. The overall effect of this was that overworked controllers could not keep up with the increasing air traffic. The resulting delays and inefficiencies clearly indicated that at the rate of current traffic growth, the existing system was completely inadequate [3].

5.4 FAA Contract with Lincoln Labs

In order to realize ATCAC's vision of air traffic control, the FAA needed to find an organization which would be able to take the loose collection of requirements that ATCAC had proposed and turn them into a fully specified system, keeping in mind the requisite compatibility issue. Lincoln Laboratory, ultimately, became the "technical arm" [15] for the FAA.

In 1971, the FAA signed its first contract with Lincoln Labs for a total of \$140,000 to explore the design of a new air traffic control technology. The project was entitled Discrete

Address Beacon System (DABS), and the FAA emphasized compatibility as its primary concern in order to satisfy the needs of the aviation community [13]. Lincoln's first task was to put together a technical development plan that would convince the FAA that the venture was technologically possible; to "design a new beacon system that would not only be compatible with the old system, but could employ the same aircraft antennas and operate in the same frequency band." [13] After the success of this six month planning project, the FAA contracted Lincoln Labs to develop and test DABS, later called Mode S.

Chapter 6

Mode S Development

When the Air Traffic Control Group at Lincoln Labs began its work on the development of Mode S, interoperability with the old ATCRBS system was its primary concern. There were two important components to interoperability: backwards compatibility and transparency. Backwards compatibility allows Mode S to work constructively with ATCRBS, while transparency ensures that the new Mode S signal will not disrupt the operation of existing ATCRBS ground stations and transponders. As illustrated in Figure 6.3, a Mode S transponder needs to work with both ATCRBS and Mode S ground stations.

6.1 Mode S Overview

In general, ground station sensors use interrogations to try to communicate to aircraft in its vicinity. Each aircraft contains a transponder that automatically responds to interrogations from ground sensors. Upon receiving an interrogation, the transponder sends back a reply containing information such as plane identification or altitude reports. Prior to Mode S, interrogations were general broadcasts, and any transponder that received an interrogation signal would respond. As air traffic increased, these extra replies caused congestion problems in the 1030/1090 MHz communication channels. In contrast, Mode S is discretely addressed, so each interrogation generates only one response.

In a discrete addressing system, each plane has a unique identification code. Interrogations sent from the ground sensor carry the identification of the targeted plane. When other aircraft receive interrogations not addressed to them, they do not respond. Mode S uses the same interrogation-reply sequence as ATCRBS to track planes, but requires fewer sequences, thus reducing the traffic on existing communication channels.

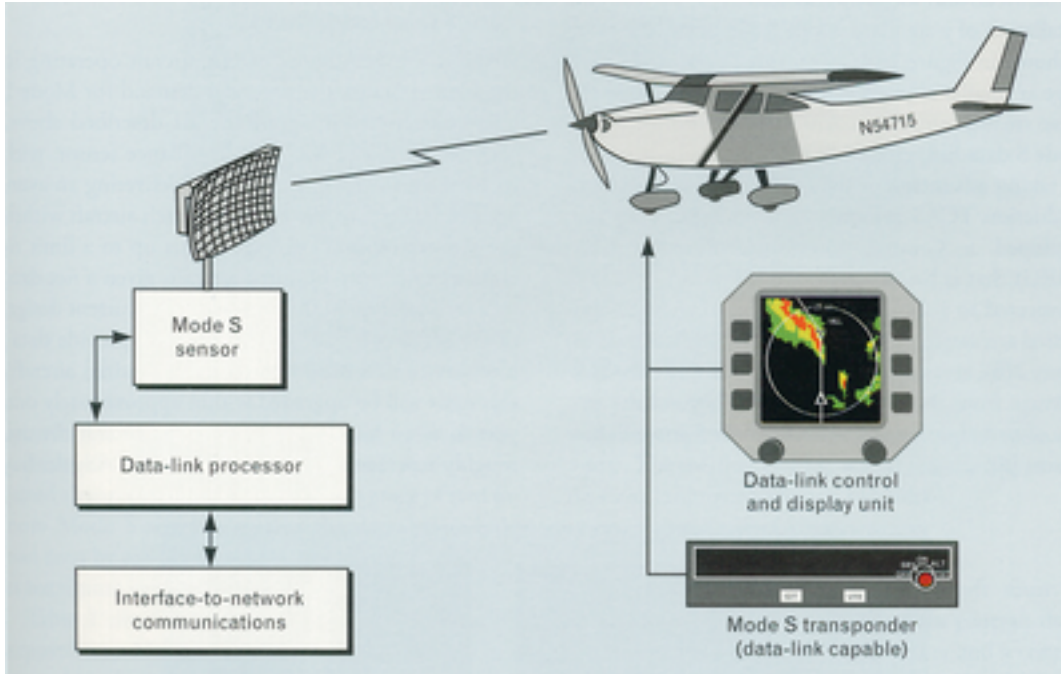

Figure 6.1: Mode S Overview

6.2 Backward Compatibility

The Lincoln Laboratory researchers estimated that by the time Mode S could be deployed, there would be more than 200,000 aircraft equipped with ATCRBS transponders and 500 ATCRBS ground stations that would need to be upgraded [16]. Although modifying all ATCRBS sensors and transponders was technically feasible, this approach was not “practical for economic reasons and was not considered as [a] serious possibilit[y] until all other possibilities had been explored and exhausted.” [17] Modifying existing equipment translated to high labor and parts costs for all members of the aviation community. In addition, the time required for a complete upgrade of all existing equipment would be prohibitively long. Since air traffic control systems run 24 hours a day, 7 days a week, they can never be shut down for a systems upgrade. As one researcher noted, “in air traffic control, there is no instantaneous reset.” For these reasons, the researchers understood that Mode S needed to be designed in a way that “permit[ted] a gradual, economic transition...over a 10-to-15 year period.” [18] Interoperability became a necessity.

Interoperability imposed a number of different constraints on the effort to develop components for the new system. Because ATCRBS sensors were only capable of sending ATCRBS interrogations and interpreting ATCRBS replies, Mode S transponders had to be backwards compatible. Any aircraft had to be detected by both unmodified existing stations and new ground stations. This meant that the Mode S transponders had to be able to understand and reply to ATCRBS interrogations [12]. Without this functionality, Mode S transponders would not be able to communicate with ATCRBS ground sensors.



Figure 6.2: Mode S Ground Station and Antenna

Conversely, Mode S ground sensors also had to be able to transmit and process the signals used by ATCRBS transponders. Because the AOPA had strongly argued to the FAA that air traffic control systems had to be built that would serve all users, the Lincoln Lab researchers searched for a way to allow “a high degree of compatibility in transponder functions between ATCRBS and [Mode S] transponders.” [19]

The need for interoperability would ultimately influence many of the other decisions during Mode S development. In particular, the choice of frequency and the design of the Mode S signal were driven exclusively by the need for interoperability.

6.2.1 Frequency Choice

Frequencies are the communication channels that transponders and sensors use to exchange messages. The existing ATCRBS system operated on two frequencies: 1030 and 1090 MHz. Ground stations used the 1030 MHz ‘uplink’ channel to interrogate nearby planes, and planes responded on 1090 MHz ‘downlink’ channel.

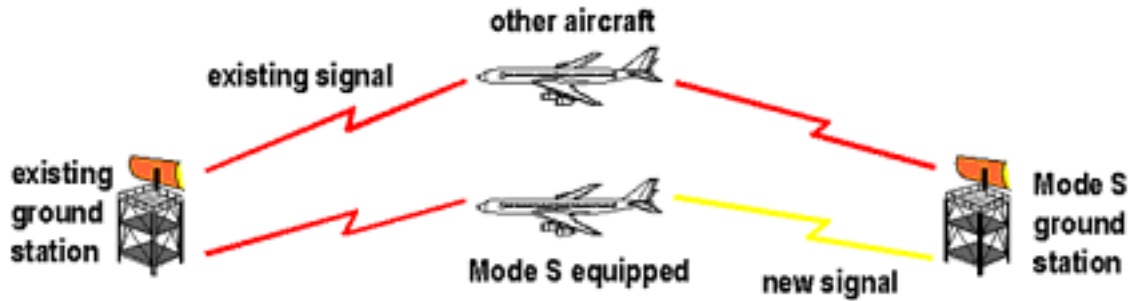

Figure 6.3: Interoperability: ATCRBS and Mode S

The decision to use these same frequencies for Mode S was the focus of considerable debate. “The neatest technical solution would have been to put it on its own [frequency] band,” said Paul Drouilhet [12]. If Mode S had been designed to operate on unused frequencies, the system would have had no chance of interfering with the existing ATCRBS system; the interactions of one system would have remained completely independent of the other.

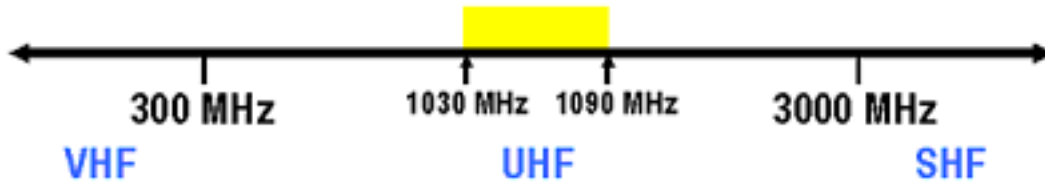

Figure 6.4: Frequency Spectrum

However, if Mode S used a new frequency band, its transponders would be unable to communicate with ATCRBS sensors. Moreover, Mode S sensors would not be able to communicate with ATCRBS transponders. Since the goal of Mode S was to install a new system without “messing up the old system,” the decision was made to choose the 1030 and 1090 MHz frequencies for Mode S uplink and downlink transmission [20]. Using the same frequencies as the existing system makes cross-communication trivial. However, the new challenge was to provide the ability for both systems to operate seamlessly, without interference.

6.3 Transparency

Even though both systems used the same frequency for communication, the Mode S signal needed to be transparent to existing ATCRBS equipment. In other words, the Mode S signal had to be designed so that ATCRBS equipment would never attempt to interpret the signals. This problem was challenging on many levels, but ultimately, the Lincoln Labs researchers found a clever way to exploit an existing feature of the ATCRBS system and ensure transparency.

6.3.1 Invisibility

When Lincoln Labs chose to use the same 1030/1090 MHz frequencies, the Mode S design problem became much more challenging, because Mode S would have to share the communication channel with the existing ATCRBS system. The most obvious solution would be to create a Mode S waveform that would be ignored or go unnoticed by ATCRBS transponders.

This initial idea had the added benefit of being cost-efficient, because no modifications would be needed to existing transponders. The researchers had experimented with different modulating schemes including frequency shift keying (FSK) and phase shift keying (PSK) hoping that the ATCRBS transponders would simply ignore these signals. In addition, they attempted to vary pulse widths and the time intervals between pulses in search of a waveform that would not elicit a response.

A general field test of transponders used at the time revealed that no such universally “invisible” waveform could be found. Not one signal went unnoticed by all of the available transponders. One of the problems was that at this time, there were more than five hundred transponders available on the market for use in commercial jets, military aircraft, and private planes. The companies that manufactured these transponders, which included Collins, Bendix, and Wilcox all claimed to adhere to the specifications outlined by the FAA’s National Aviation Standard (March 8, 1971). For the most part, they were compliant, but still responded to a wide range of additional signals [20].

The experimentation had revealed a fundamental flaw in the FAA’s National Aviation Standard itself. The standard had “said lots of stuff about what the ATCRBS transponder should do and nothing about what they shouldn’t do,” recalled Lincoln Laboratory researcher Thomas Goblick. For instance, several transponders would even respond to sinusoidal waveforms [17] even though these signals were extremely simple and not mentioned in the specification. Because transponders exhibited such a diverse range of behavior, finding and proving the applicability of a universally “invisible” signal was impossible. The Lincoln Laboratory researchers needed to find a workaround. Ironically, their solution led full circle back to an existing ATCRBS feature known as sidelobe suppression.

6.3.2 Sidelobe Suppression

Sidelobe suppression was a technique that had been implemented in many radar systems, including ATCRBS, to solve a common problem. This problem occurred due to signal leakage in the directional antenna. When interrogation signals are transmitted with a directional antenna, the signal often leaks through the sides of the antenna. These leaked signals are called sidelobe signals. Aircraft flying close to the antenna picked up these sidelobe signals and responded to them, causing interference on the channel.

The general solution to this problem was to add an additional pulse to provide additional information to receiving aircraft. Under this system, the interrogation signal consists of two pulses, P1 and P2. The first pulse P1 is sent by the directional antenna. A second, weaker

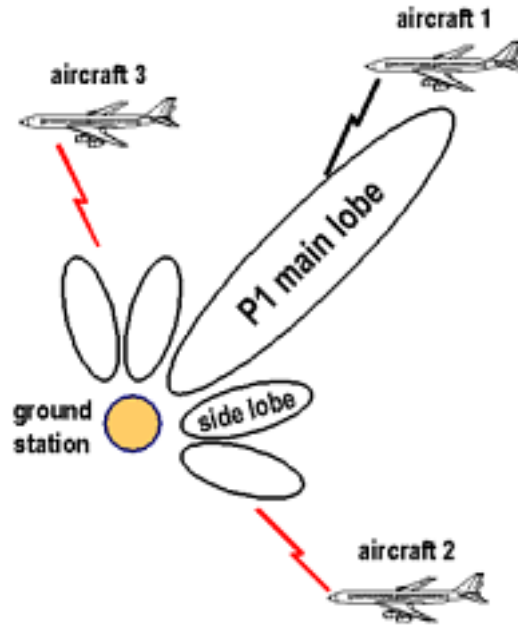

Figure 6.5: ATCRBS Broadcast without Omnidirectional Antenna

pulse P2 is sent immediately after P1 by an omnidirectional antenna. Although this P2 pulse is weaker than the main lobe of P1, it is stronger than the sidelobe signals.

The effect of this is that planes pointed to by the directional antenna will receive a signal in which P1 is significantly stronger than P2. Planes in any other direction will receive a signal in which P2 is equivalent to or stronger than P1. The transponders on the planes compare the first two pulses in any transmission, and reply only if P1 was distinctly stronger than P2.

As shown in Figure 6.6, transponders in aircraft flying near the antenna in the sidelobes receive signals with P1 approximately equal to P2. In this case, the transponder is temporarily disabled, or “suppressed,” for approximately 35 microseconds, preventing it from replying to the leaked interrogation signal.

6.3.3 Taking Advantage of Sidelobe Suppression

When Lincoln Labs researchers realized that they could not find an “invisible” waveform that would cause ATCRBS transponders to passively ignore the Mode S signal, they devised a way to take advantage of sidelobe suppression and cause ATCRBS transponders to actively ignore the Mode S signal. Because the suppression mechanisms of ATCRBS transponders were known to be “more carefully and uniformly controlled than the mechanisms for rejecting non-standard signals in the ATCRBS band” [21], a Mode S sensor could send a signal without accidentally triggering responses from ATCRBS transponders. The Mode S waveform was carefully designed so that it begins with a signal of two equivalent pulses, the same signal

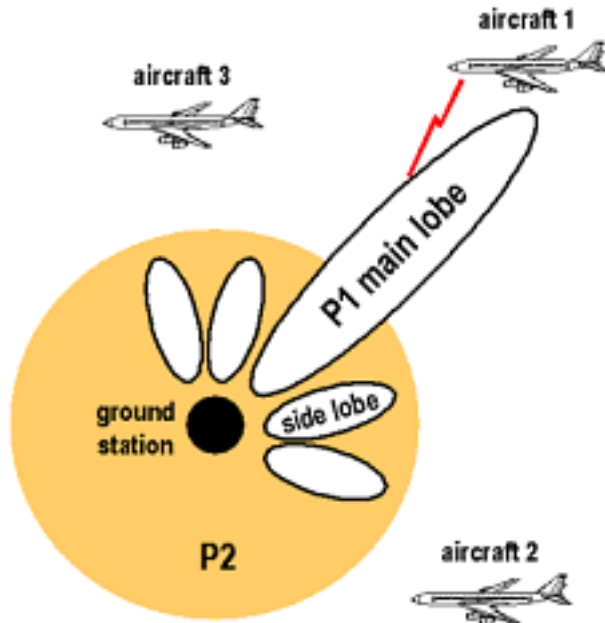

Figure 6.6: ATCRBS Broadcast with Omnidirectional Antenna

that suppresses ATCRBS transponders. During the time in which ATCRBS transponders are temporarily disabled, the remainder of the Mode S data is transmitted to the intended aircraft.

This clever application of sidelobe suppression signals was neither the cleanest nor the most extensible solution to the transparency problem, but it was the best functional option at the time. Because the Mode S signal was based on a feature of ATCRBS, some ATCRBS limitations became limitations in Mode S. One of these limitations is the suppression window. Because of the short duration of transponder suppression, only a limited number of bits can be sent. Transponder tests had demonstrated that there were a significant number of accidental replies when transmitting messages longer than 200 bits; these messages were exceeding the window of suppression.

The researchers attempted to extend this window by trying to re-disable the transponders while they were in suppression mode. However, the circuitry in transponders could not be re-triggered while still in suppression mode, so the time could not be extended. Thus, the researchers had to design a system that would work within the 35 microsecond interval. Ultimately, in order to maximize the number of transponders that could interoperate with Mode S, the Lincoln Lab designers restricted the message length to 112 bits.

The final transmission protocol for Mode S interrogations would involve suppressing all ATCRBS transponders in the coverage area before sending out replies. This approach allowed Mode S data blocks to be transmitted in the 1030/1090 MHz channel, as long as they were preceded by the suppression preamble.

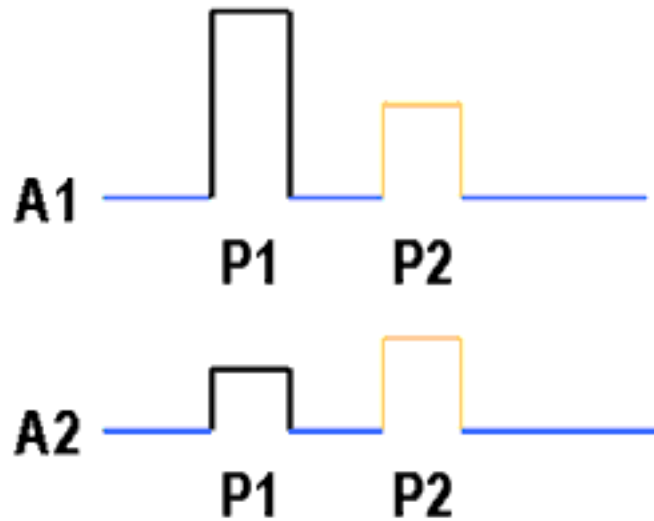

Figure 6.7: ATCRBS Broadcast Pulses

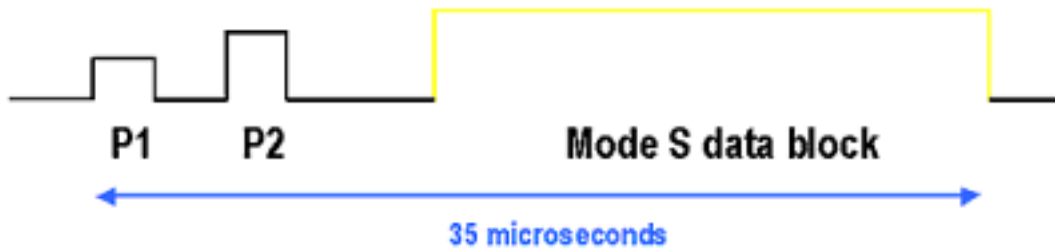

Figure 6.8: Mode S Signal with Sidelobe Suppression

6.3.4 Modulation

Some design choices, such as modulation, were indirectly affected by the need for interoperability. Modulation is the process by which a signal is encoded for transfer over a data link, and demodulation is the process by which it is decoded upon receipt for further processing. Different modulation schemes have varying ability to deal with noise and interference. In the case of Mode S, the choice of using interoperable frequencies affected modulation because interference became a large concern. However, the easiest way to ensure backwards compatibility was to make as few equipment changes as possible. This approach was also endorsed by the contractors that would eventually manufacture the equipment since it required fewer changes to their production and testing facilities. In the end, a compromise was reached that utilized a combination of old and new modulation techniques.

During the development of Mode S, Lincoln Lab researchers relied on contractors who had already developed ATCRBS sensors and transponders [19]. In doing so, these researchers

sought the contractors' experience to help ensure interoperability. Rather than redesigning the avionics equipment, the researchers sought to only redesign the circuitry and logic needed to support Mode S. The primary motivation for minimizing the amount of redesign for existing transponders was the cost of manufacturing new transponders. In addition, this approach minimized backwards compatibility issues.

The reuse of avionics equipment to guarantee backwards compatibility strongly influenced the modulation choices in the Mode S system. Lincoln Labs evaluated different modulations schemes such as Pulse Amplitude Modulation (PAM), Frequency Shift Keying (FSK), and Differential Phase Shift Keying (DPSK), to determine which would be most resistant to interference. Based on their calculations, they concluded that PAM was more vulnerable to interference than the other candidates [22].

Initial calculations also confirmed that the most promising modulation scheme, DPSK, did in fact exhibit the best performance. However, PAM modulation had been used for both uplink and downlink transmission in ATCRBS. In addition, the circuitry was inexpensive and easy to implement, even though theoretical calculations showed that it would be least resistant.

The researchers faced an uphill battle to convince the FAA and manufacturers of transponder companies to use DPSK modulation. "It was a hard sell," reflected Goblick. "[They] were not used to this technology and its production problems." There had also been some question among the researchers whether DPSK demodulation could be implemented at an affordable cost [22].

To help answer these questions, in 1973 Goblick and other Lincoln Laboratory researchers requested several companies, including Bendix, Hazeltine, and Collins, to design transponders with PAM and DPSK modulation [19]. The results of these experiments indicated that the cost of implementing DPSK for uplink modulation would only be slightly higher than using PAM. "The cost-effective choice is DPSK for the [Mode S] uplink," concluded Goblick in a report to the FAA in 1974 [19].

However, the recommendations for the downlink was not to use DPSK. The additional transmitter that would be needed on a transponder had been found to increase the cost by more than 20%. "One of the FAA officials was adamant," recalls Goblick. "I want things absolutely low-cost." As a result, pulse-position modulation (PPM), a form of PAM modulation with a slightly better resistance to ATCRBS interference, was chosen.

The selection of the modulation scheme was a direct product of the desire to maintain interoperability, through the choice of frequency. In the old ATCRBS system, ground stations would often receive replies even when they had not recently sent an interrogation. The resulting situation was known as a FRUIT (False Replies Uncorrelated in Time) environment. The Lincoln Lab researchers had been inclined to select DPSK because it provided the most resistance to the interference caused by the ATCRBS FRUIT environment. When cost constraints discouraged the use of this modulation for the downlink transmission, the researchers opted to use PPM, which provided slightly better resistance than PAM.

6.3.5 Summary

Interoperability imposed many constraints on the design decisions for Mode S. Identical frequency, backwards compatibility, and signal transparency were just some of the design decisions that addressed interoperability. In order to achieve interoperability with the existing ATCRBS system, Mode S had to be able to monitor aircraft using both Mode S and ATCRBS transponders. In addition, the Mode S system had to be designed to permit ATCRBS to detect and supervise not only ATCRBS equipped planes, but aircraft outfitted with Mode S as well. More specifically, to accomplish the goal of interoperability, the Mode S system had to be created so that Mode S ground sensors could communicate with ATCRBS transponders on planes. Conversely, ATCRBS ground sensors had to be capable of communicating with Mode S transponders. All of these issues needed to be resolved without modifying any of the hardware already in use in the ATCRBS system.

Chapter 7

Aftermath

7.1 A Slow Adoption

Lincoln Labs finished a comprehensive proposal and design for the Mode S system and delivered it to the FAA in 1975. In addition, Lincoln Laboratory assisted the FAA in developing and testing three commercial prototype Mode S sensors. These prototypes clearly demonstrated that the finished design could be used to manufacture commercial sensors [13]. However, despite Lincoln Labs' attention to interoperability and efforts to minimize transition costs, Mode S was not promptly deployed.

Deployment of the Mode S transponders ultimately depended on the manufacturing companies. After all, as Drouilhet said, "The lab exists to be a capable technical resource to help figure out how to solve the problems...then industry builds it." [12] Companies contracted to produce the Mode S sensors altered Lincoln Labs' design so that they could be more easily produced using existing production facilities. The resulting modifications caused problems, creating delays in producing the sensors. For instance, a contract with Texas Instruments (TI) to produce Mode S sensors fell apart when TI decided to implement the system software using smaller, less powerful TI machines instead of a mainframe. This change required a software rewrite, and subsequent problems were so severe that the contract was terminated [20]. Similar problems occurred with other contractors such as Westinghouse and UNISYS [13]. Because of these setbacks, few Mode S ground sensors and *no* commercial Mode S transponders were made available before 1980.

7.2 An Accident Spawns Change

A tragic mid-air collision over Cerritos, CA on August 31, 1986 prompted a dramatic change. During the initial approach to Los Angeles International Airport, an Aeromexico DC-9 passenger plane collided with a small Piper aircraft carrying a family of three, killing all 67 passengers aboard the planes. An additional fifteen people on the ground were also

killed [23]. The accident was blamed on inadequate automatic conflict alert systems and surveillance equipment, and Congress responded by passing the Airport and Airway Safety and Capacity Expansion Act in December, 1987. This law required that all carrier aircraft operating within U.S. airspace with more than 30 passenger seats would have to be equipped with TCAS (Traffic Collision Avoidance System) II by 1993. Aircraft with 10 to 30 seats were required to employ TCAS I [24].

7.3 TCAS

The Traffic Collision Avoidance System is the product of a joint effort between Lincoln Laboratory and MITRE. Like Mode S, TCAS was supported by Lincoln Labs from proof of concept through design and testing to publication of final international standards. Formerly called BCAS (for Beacon Collision Avoidance System), TCAS is an instrument integrated into other systems in an aircraft cockpit. It is designed to “provide a set of electronic eyes so the pilot can ‘see’ the traffic situation in the vicinity of the aircraft.” [23] The TCAS system uses three separate systems to plot the positions of nearby aircraft. First, directional antennae that receive Mode S transponder signals are used to provide a bearing to neighboring aircraft. This system is accurate to a few degrees of bearing. Next, Mode C altitude broadcasts are used to plot the altitude of nearby aircraft. Finally, the timing of the Mode S interrogation/response protocol is measured to ascertain the distance of an aircraft from the TCAS aircraft.

The first implementation of TCAS, TCAS I, allows the pilot to see the relative position and velocity of all aircraft within a 10-20 mile range. More importantly, TCAS has a traffic advisory capacity which provides a warning when an aircraft in the vicinity gets too close. TCAS I does not provide instructions on how to maneuver in order to avoid the aircraft, but does supply the pilot with important data for him to make the maneuvers [23].

TCAS II provides pilots with airspace surveillance, intruder tracking, threat detection, and avoidance maneuver generations. TCAS II is able to determine whether each aircraft is climbing, descending, or flying straight and level, and suggests an evasive maneuver necessary to avoid the other aircraft. If both planes in conflict are equipped with TCAS II, then the evasive maneuvers will be well-coordinated via air-to-air transmissions over the Mode S datalink; the proposed maneuvers will not cancel each other out [23].

7.4 The Mode S Legacy

“TCAS was what made Mode S real, and what entrenched Mode S as a lasting technology.”
– Jonathan Bernays, Lincoln Labs researcher

Due to the Congressional mandate, TCAS became a pervasive system for air traffic control centers around the world. Because TCAS uses Mode S as the standard air-ground commu-

nication datalink, the widespread international use of TCAS has helped Mode S become an integral part of air traffic control systems all over the world.

An additional advantage of Mode S is its flexible design, which has made it a possible platform for a variety of other applications. In the July, 1980 OTA Seminar on DABS, Quentin Taylor of the FAA notes, “[Mode S] adds improved surveillance quality, discrete aircraft addressing function, and the technical base for a digital communication exchange system. The latter is obviously a very important feature.” [25] The datalink capacity of Mode S has spawned the development of a number of different services that take advantage of the two-way link between air and ground. By relying on the Mode S datalink, these services can be inexpensively deployed to serve both the commercial transport aircraft and general aviation communities. Using Mode S makes several services available to the general aviation community which were previously accessible only to commercial aircraft. Two of these services, the Graphical Weather Service and the Traffic Information Service, were developed by Lincoln Labs [26].

7.4.1 Traffic Information Service

The Traffic Information Service (TIS) provides many of the functions available in TCAS; unlike TCAS, TIS is a ground-based service available to all aircraft equipped with Mode S transponders. TIS takes advantage of the Mode S data link to communicate collision avoidance information to aircraft and presents this information to a pilot in a cockpit display as illustrated in Figure 7.1. This cockpit display shows traffic within five nautical miles and a 1200 feet altitude of Mode S-equipped aircraft. The TIS system uses track reports provided by ground-based Mode S surveillance systems to retrieve traffic information [27]. Because it is available to all Mode S transponders, TIS is an inexpensive alternative to TCAS; its availability makes collision avoidance technology more accessible to the price-sensitive general aviation community.

7.4.2 Graphical Weather Service

The Graphical Weather Service provides a graphical representation of weather information that is transmitted to aircraft and displayed on the cockpit display unit (see Figure 7.2). The service is derived from ground-based Mode S sensors and offers information to all types of aircraft, regardless of the presence of on-board weather avoidance equipment. The general aviation community has been very pro-active in evaluating this technology, as they have already participated in field evaluations in Mode S stations across the U.S. [27].

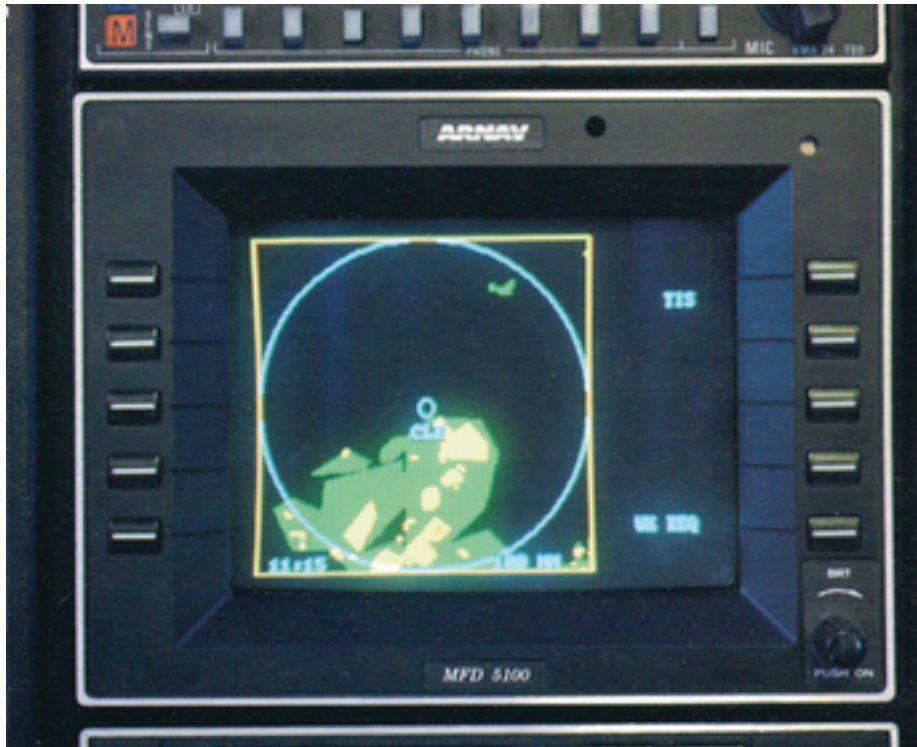

Figure 7.1: A Traffic Information Service Display in a Cessna

7.5 Mode S Extended Squitter

The most recent and most compelling use of Mode S has been in the area of Automatic Dependent Surveillance-Broadcast (ADS-B). Under ADS-B, each aircraft periodically broadcasts its identification, position, and altitude. These broadcasts can be received by ground sensors and other aircraft for surveillance. This system of broadcast addresses the major deficiency of TCAS – accuracy. In the TCAS system, aircraft positions are only accurate to a few degrees; thus, the accuracy of TCAS decreases with distance. Moreover, the reliance on transmission timing for range data in TCAS is error-prone. The method used by ADS-B avoids this problem.

The Mode S extended squitter (also known as the GPS squitter) is a component of ADS-B which was proposed, developed, and demonstrated by Lincoln Labs. A participating aircraft broadcasts (“squits”) positional information using a modified Mode S transponder. The positional information comes from a source of global navigation, such as a Global Positioning Satellite (GPS) receiver. The Mode S extended squitter is a smooth upgrade from traditional Mode S. According to Steve Bussolari, project leader at Lincoln Labs, “The notion behind the Mode S extended squitter is that it works seamlessly with the existing system.” [28] Paul Drouilhet adds, “The GPS squitter is an expansion of the signal...What has changed is that GPS squitter adds to the broadcast, GPS info...the previous Mode S squitter [just] broadcasts altitude. The GPS Squitter has taken [Mode S], added more bits and in those bits, transmits information as derived from GPS.” The Mode S extended squitter was demonstrated by

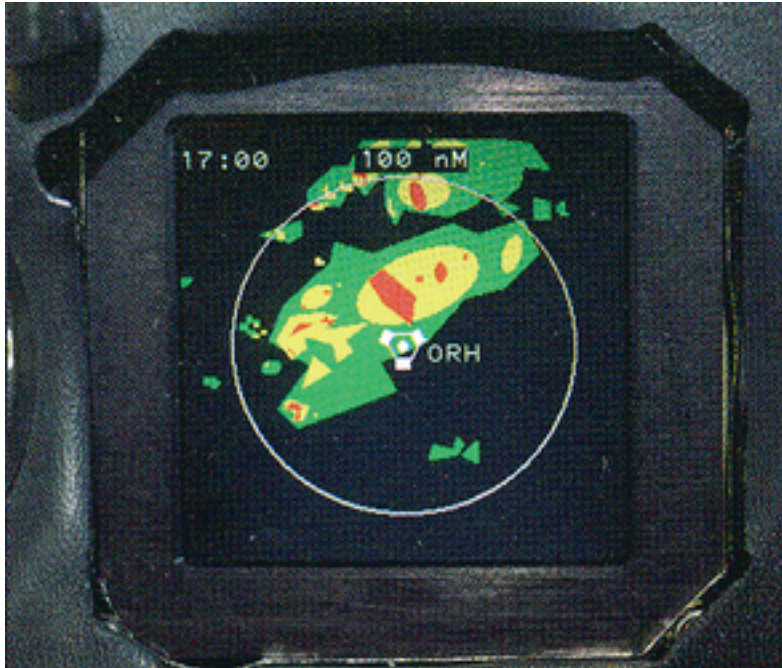

Figure 7.2: Graphical Weather Service Cockpit Display

Lincoln Labs and the FAA in Boston and the Gulf of Mexico in 1994, and is one of three candidates being considered by the FAA for ADS-B.

7.6 Success and Failure

Quantifying success and failure is difficult. One way to characterize success is to assess the importance and prevalence of the technology. By this metric, Mode S is indeed successful. Today, Mode S ground stations are being deployed at 108 of the nation's busiest airports. In addition, the majority of aircraft landing at these airports are equipped with Mode S transponders. Mode S is an international standard and the existing ATCRBS based system is being phased out. Without Mode S technology, the 1030/1090 MHz frequency band would be completely overloaded, especially around busy airports. Mode S is now a critical component of the world's core air traffic control infrastructure.

Mode S is also a success from the perspective of fulfilling its key requirement of interoperability. The perfect interoperability of Mode S with the existing air traffic control system has enabled the incremental roll-out of Mode S technology in both ground stations and aircraft, and allowed existing air traffic control infrastructure to scale seamlessly to accommodate increasing air traffic densities.

A final definition of success would be a validation of the original idea that a two way, one-to-one datalink would be a generally useful application. The ATCAC recommendation in December 1969 that the next generation of air traffic control technology should be a one-to-

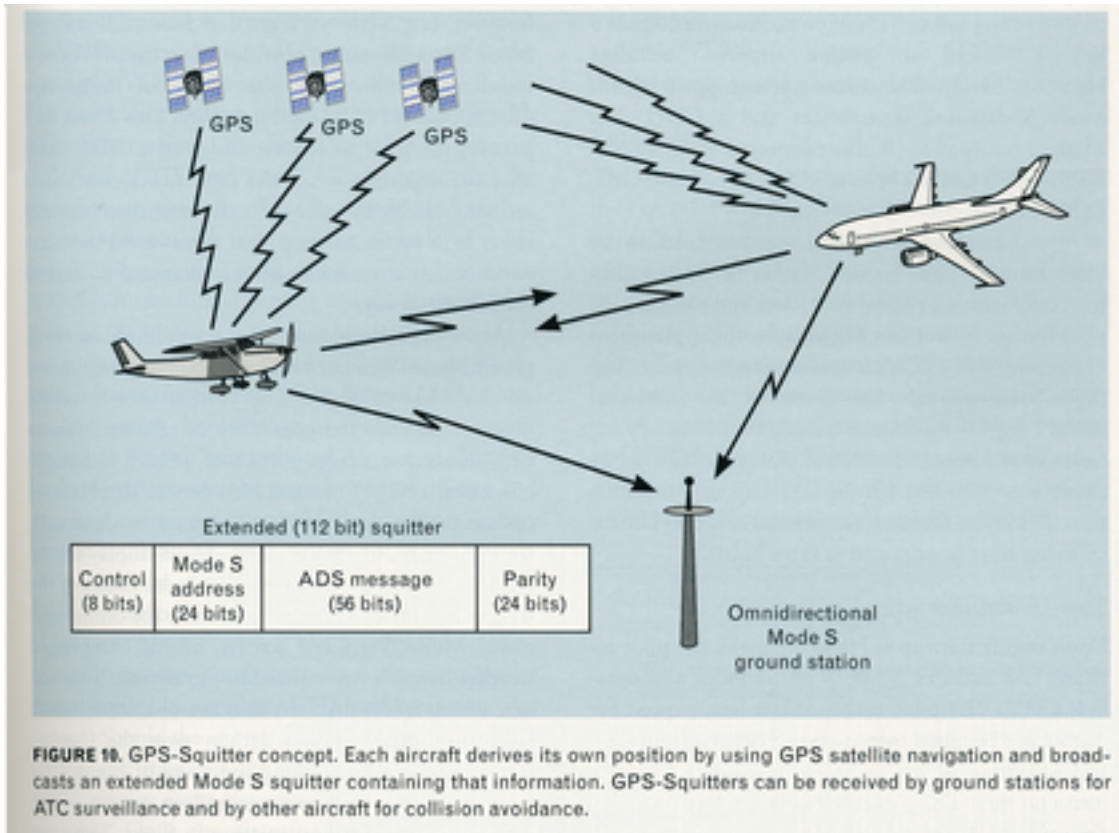

Figure 7.3: Mode S Extended Squitter System

one datalink was remarkably prescient. The number of applications that use Mode S being developed and used today – TIS, the Graphical Weather Service, Mode S extended squitter, TCAS – is a testament to the foresight of the designers of the Mode S system and those who drove its requirements.

Chapter 8

Conclusions

A thorough investigation of Mode S and its design has made it eminently clear that interoperability was the driving influence in the design of Mode S. Nearly every design decision, from the frequency choice to the waveform design was constrained by this concern, leading to several ingenious solutions for integrating the new system with the old.

The primary reason for this requirement was the needs of the aviation community. Being diverse in interests and large in size, this group is alternately safety-conscious, economical, skeptical, and concerned about the bottom line. The overall effect is extreme conservatism, which has two major consequences for designers of air traffic control systems. First, deployment of a new air traffic control technology is always incremental; there will always be a long transition period during which both new and old systems must coexist. Adoption of a new air traffic control technology requires upgrading hundreds of ground stations, installing new equipment in thousands of aircraft, and training tens of thousands of people. Second, a new air traffic control system cannot assume that every aircraft will be fully compliant with the new standard. The global nature of aviation and the relative ease with which a pilot may fly aircraft virtually guarantees that some aircraft may not have the latest in air traffic control technology.

Air traffic control is a unique problem in that every aircraft in a given airspace must be tracked by a ground station. In a hybrid system, both systems must be able to operate in conjunction with the components of the other, in order to ensure the safety of all aircraft. For this reason, any new air traffic control system must be interoperable, ensuring that the new technology can seamlessly work together with the existing air traffic control infrastructure.

Mode S succeeded because it was designed with interoperability in mind. The Lincoln Labs designers considered the interests of the aviation community and the FAA in designing the system, and built an interoperable air traffic control system. The Lincoln Labs design of Mode S made several performance compromises in the interest of cost minimization, ease of integration, and ability to coexist cooperatively with the existing technology. Mode S shared the same frequency for uplink and downlink transmissions as ATCRBS, and the Mode S waveforms were designed to work with existing ATCRBS transponders and sensors.

Modulation schemes resistant to high interference environments were chosen. In addition, the design accommodated a hybrid system composed of both ATCRBS and Mode S, allowing for a long transition period. Mode S was successful because it was not developed in isolation.

Furthermore, designing any successful technology in isolation is impossible. The design of a technology is influenced by many factors – the sponsors of the research have their own priorities, the future users of the technology influence its development, the designers have a set of design experiences from which they draw upon – that cannot be avoided. In fact, designers should embrace the idea that technologies cannot be developed in isolation, and capitalize on the benefits of all of these influences. Designers should hear the concerns of each group of users, generalizing the common themes into guiding goals for the system. In addition, they should examine past designs for similar technologies, and take advantage of useful design patterns. Technologies cannot be developed in isolation, and moreover, successful technologies never are; rather, they are designed by embracing the diverse interests of the communities into which they are born.

Chapter 9

Acknowledgments

The authors of this paper wish to acknowledge the members of the Lincoln Laboratory, FAA, MITRE, and AOPA who provided time from their busy schedules to help us with this project: Jonathan Bernays, Neil Blake, Bob Boisvert, George Colby, Steve Bussolari, Robert Everett, Bill Harman, Paul Drouilhet, Thomas Goblick, Edmund Koenke, Warren Morningstar, Vincent Orlando, Jack Ruina, David Shnidman, Ann Tenford, Herb Weiss, Loren Wood, and Gene Wong. We are especially grateful for those who offered to be interviewed.

We also wish to thank the members of the MIT Retrospective Collection (RSC), who we relied upon to provide us all the technical reports and books related to air traffic control, Andrew Chiu and Cindy Liang for attending our presentation rehearsals, Mark Silis for providing emergency support when our CVS directory disappeared, and Professor David Mindell, Professor George Pratt, and Eden Miller for providing us with feedback and guidance for this project.

Bibliography

- [1] Philip I. Ryther. *Who's Watching the Airways*. Federal Aviation Administration, January 1972.
- [2] Richard J. Kent. *Safe, Separated and Soaring*. US Department of Transportation, 1980.
- [3] Michael S. Nolan. *Fundamentals of Air Traffic Control*. Brooks/Cole Publishing Company, Pacific Grove, CA, 1998.
- [4] V.A. Orlando and J.D. Welch. *Traffic Alert and Collision Avoidance System (TCAS): A Functional Overview of Active TCAS I*. Lincoln Laboratory, April 8 1983.
- [5] Jean Baker. *Plane Talk*. StuckMic.com, <http://www.stuckmic.com/editorials/jeanbaker/planetalk.html>, April 1999.
- [6] Jack Ruina. *Interview*. MITRE Corporation, December 2000.
- [7] In *Report of Department of Transportation Air Traffic Control Advisory Committee*, December 1969.
- [8] Robert Everett. *Interview*. MITRE Corporation, December 2000.
- [9] AOPA, <http://www.aopa.org/info/history.html>. *AOPA Online - History of AOPA*.
- [10] Max Karant. *My Flights and Fights*. McGraw-Hill, 1999.
- [11] Air Transport Association, <http://www.air-transport.org/public/Handbook/Default.htm>. *Airline Handbook*, 2000.
- [12] Paul Drouilhet. *Interview*. Lincoln Laboratories, December 2000.
- [13] Eva C. Freeman. *Technology in the National Interest*. Nimrod Press, Boston, 1995.
- [14] Neal Blake. *Interview*. Federal Aviation Administration, December 2000.
- [15] Herb Weiss. *Interview*. Lincoln Laboratories, December 2000.
- [16] P. R. Drouilhet. *DABS: A System Description*. Lincoln Laboratory, November 18 1974.
- [17] J. R. Samson, J. D. Welch, E. R. Becotte, E. A. Crocker, and H. D. Schofield. *Final Report DABS/ATCRBS Transponder Bench Testing Program*. Lincoln Laboratory, November 28 1973.

- [18] Jonathon Bernays. *Interview*. Lincoln Laboratories, December 2000.
- [19] T. J. Goblick and P. H. Robeck. *A Summary of the DABS Transponder Design/Cost Studies*. Lincoln Laboratory, March 1 1974.
- [20] Thomas J. Goblick. *Interview*. Lincoln Laboratories, December 2000.
- [21] T. J. Goblick. *DABS Modulation and Coding Design*. Lincoln Laboratory, March 12 1976.
- [22] D. A. Schnidman. *A Comparison of Immunity to Garbling for Three Candidate Modulation Schemes for DABS*. Lincoln Laboratory, August 14 1972.
- [23] The MITRE Corporation, <http://www.caasd.org/proj/tcas/#skies>. *TCAS - Traffic Alert and Collision Avoidance System*, October 2000.
- [24] Airline Pilots Association, <http://www.house.gov/transportation/aviation/avhearin/tcas/babbitt.htm>. *Statement of Airline Pilots Association before the Subcommittee on Aviation*, February 1997.
- [25] *Proceedings of the OTA Seminar on the Discrete Address Beacon System (DABS)*, Washington, D.C., July 1980.
- [26] Steven R. Bussolari. Mode s data-link applications for general aviation. *The Lincoln Laboratory Journal*, 7(2), 1994.
- [27] FAA, <http://www.faa.gov/and/and300/datalink/navsur/gps.htm>. *GPS Squitter Technology*.
- [28] Steve Bussolari. *Interview*. Lincoln Laboratories, December 2000.